

KALLIOPI KARYDA & CO, LP  
87A, 17is Noemvriou str.  
55535, Pylaia, Thessaloniki  
Tel. 2316 006600  
Fax. 2316006650  
[www.united-electronics.gr](http://www.united-electronics.gr)



# UNITED

EN Refrigerator / Instructions manual

BEFORE USE, PLEASE READ AND FOLLOW ALL  
SAFETY RULES AND OPERATING INSTRUCTIONS.

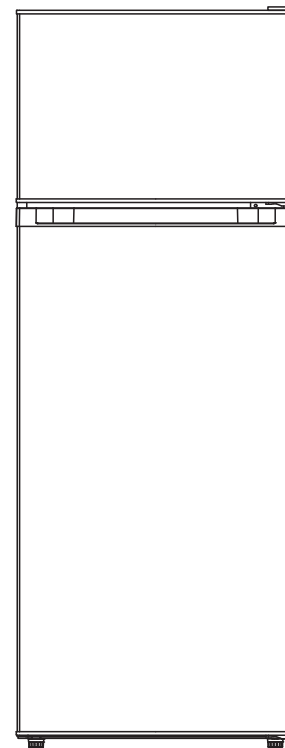

UDW2805NF  
UDX-2806NF

## CONTENTS

Names of the parts .....	1
Visit our website to .....	2
Safety warnings .....	2
Installation instructions .....	4
Reverse and install the doors.....	4
Operation instructions.....	8
Instruction for usage.....	8
Packing and moving.....	9
Maintenance.....	9
Defrost.....	9
Disconnecting the appliance.....	10
User notifications.....	11
Troubleshooting tips.....	11
Specifications and parameters.....	12
Hints and tips.....	13
Technical data.....	16
Information for test institutes.....	16
Environmental concerns.....	16
Packing list.....	17

- Thank for purchasing our products and thank you for placing your confidence in us.
- Please read this manual carefully before using. Follow instructions and keep it for future reference.
- Please follow the operating instructions and safety notices in the manual.
- If any trouble arise, do not fix it yourself or hand it to the after sales service center which has not been authorized. Please contact the local authorized service center.

## NAMES OF THE PARTS

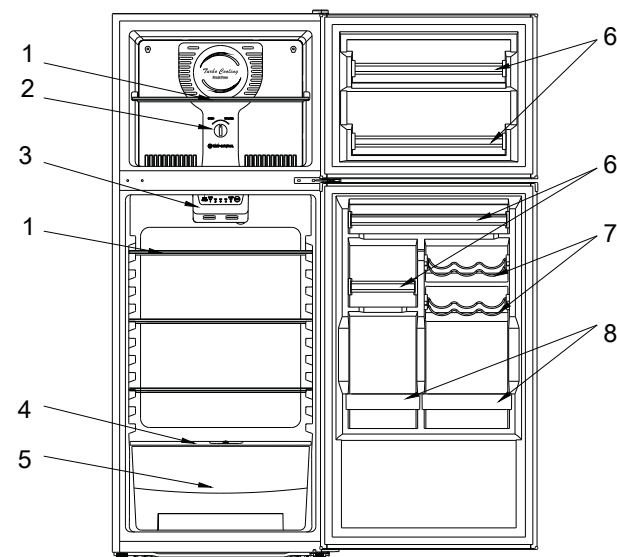

- |  |                             |
|--|-----------------------------|
| 1. Shelves                             | 5. Vegetable container      |
| 2. Wind tunnel knob                    | 6. Rod                      |
| 3. Lamp and temperature Control button | 7. Can rack in refrigerator |
| 4. Crisper glass cover                 | 8. Door tray                |

- The refrigerator you purchased may be improved, which maybe not completely consistent with the manual, However the functions and operating methods will not change. Please feel free to use!
- If you use the refrigerator for the first time, remove the adhesive tapes of the drawers, balconies, egg tray, and the drain tube plug.
- Do not pull or push the drawers and balconies fiercely during use in case of damage.
- Adjusted the temperature control as higher as you could accept, which will save the energy consumption of the refrigerator and your money;
- Don't open the refrigerator door continually if it is in the normal working situation.
- Keep the combination of drawers, baskets and shelves of the refrigerator is consistent with its original standard.

## VISIT OUR WEBSITE TO:



Get usage advice, brochures, trouble shooter, service and repair information:  
[www.united-electronics.gr](http://www.united-electronics.gr)

## SAFETY WARNINGS

**For ensure your personal safety, please follow the points below:**

1. The circuitry for refrigerator must be isolated. The area of cross section of wire must be larger than  $0.75\text{mm}^2$ . The power plug should have its own socket, the socket must be ground as adapter may cause the socket to overheat.
2. The voltage and frequency of this product should be 220-240V;50Hz. Contact with the local maintenance station or retailer if the wire is damaged.
3. Do stop the power only by pulling the power plug out of the socket directly but not by the wire.
4. Do not damage the refrigerant circuit.
5. This appliance is not intended for use by persons(including children) with reduced physical, sensory or mental capabilities, or lack of experience and knowledge, unless they have been given supervision or instruction concerning use of the appliance by a person responsible for their safety.
6. Children should be supervised to ensure that they do not play with the appliance.
7. Keep ventilation opening, in the appliance enclosure or in the built in structure, clear of obstruction.
8. Before you throw away your old refrigerator or freezer.
  - Take off the doors;
  - Leave the shelves in place so that children may not easily climb inside.
9. Do not store explosive substances such as aerosol cans with a flammable propellant in this appliance. This appliance is intended to be used in household and similar applications such as
  - staff kitchen areas in shops, offices and other working environments;
  - farm houses and by clients in hotels, motels and other residential type environments;
  - bed and breakfast type environments;
  - catering and similar non-retail applications.
10. Do not use electrical appliance inside the food storage compartments of the appliance, unless they are of the type recommended by the manufacture.
11. This appliance can be used by children aged from 8 years and above and persons with reduced physical, sensory or mental capabilities or lack of experience and knowledge if they have been given supervision or instruction concerning use of the appliance in a safe way and understand the hazards involved. Children shall not play with the appliance. Cleaning and user maintenance shall not be made by children without supervision.
12. This refrigerating appliance is not intended to be used as a built-in appliance.

Children aged from 3 to 8 years are allowed to load and unload refrigerating appliances.

To avoid contamination of food, please respect the following instructions:

- Opening the door for long periods can cause a significant increase of the temperature in the compartments of the appliance.
- Clean regularly surfaces that can come in contact with food and accessible drainage systems.
- Clean water tanks if they have not been used for 48 h; flush the water system connected to a water supply if water has not been drawn for 5 days.
- Store raw meat and fish in suitable containers in the refrigerator, so that it is not in contact with or drip onto other food.
- Two-star frozen-food compartments are suitable for storing pre-frozen food, storing or making icecream and making ice cubes.
- One-, two- and three-star compartments are not suitable for the freezing of fresh food.
- If the refrigerating appliance is left empty for long periods, switch off, defrost, clean, dry, and leave the door open to prevent mould developing within the appliance.

**WARNING:When positioning the appliance, ensure the supply cord is not trapped or damaged.**

**WARNING: Do not locate multiple portable socket-outlets or portable power supplies at the rear of the appliance.**

## NOTICE:

1. When gas leaks from its container, don't pull the plug, out or in, for it may arouse sparks and fire calamities.
2. Don't splash water on the rear of the appliance, for it may cause malfunction or electric shock.
3. Don't stor inflammabe materials such as ether, benzene, LP gas and glue etc in the refrighterator.
4. Don't place bottled beverage in the freezer, so as to prevent breaking.
5. It is better not place object on the top of appliance which is magnetic, heavy, or be filled with water. Electronic components may not work steadily if water gets inside. Do not store object which is costly or impressible to temperature and , e.g. serum, bacterin and so on.
6. The refrigerant of this product is R600a, which is inflammable. So, make sure not to damage the cooling system during the transportation and installation.
7. DISPOSAL: Do not dispose this product as unsorted municipal waste. Collection of such waste separately for special treatment is necessary.



## INSTALLATION INSTRUCTIONS

1. The refrigerator should be located in a completely flat surface , Leave 5~10 cm between each side of the appliance and the wall, and leave 30 cm between the top of the appliance and the ceiling.
2. Choose a location which is not exposed to sunlight , high temperature or humid , as humidity may cause stain.
3. Pulled out the bottom panel before installation.
4. The appliance can be adjusted by rolling its two legs in front the bottom when it is unstable. Rolling in clockwise can rise up the machine.
5. The location should be firm and flat. An un-securely position may cause noise and libration:
  - (a)The noise may be increased if the floor is not firm.
  - (b) Put a sheet under the appliance for solving the heat emission if you need to locate it onto a carpet.
6. Make sure the adjustable legs are clung to the floor, and set the appliance slope backward slightly for keeping the doors closed tightly.

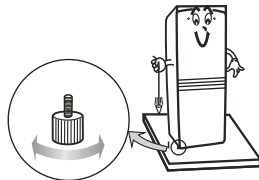
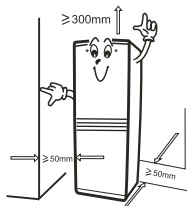

## REVERSE AND INSTALL THE DOORS

You can choose to open your refrigerator by the right side or the left one. To change the way of opening, please follow the below instructions

**Important safety warning:** before doing so please unplug and disconnect the appliance

Except the Accessories packed, you still need :

Medium-sized cross screwdriver

Small screwdriver

A solid line

One more person who can help you would be better.

1. Firstly, you need to check if the power connect or not.
2. Open the upper door, and close the bottom door.

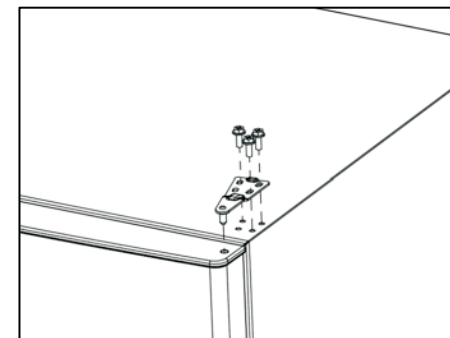
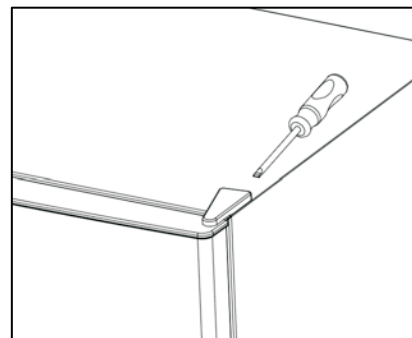

3. Take off the protective covers with a Phillips screwdriver through the back side, and save the protective covers.
4. Take off the 3 shelf-tapping screws, and save them.
5. Push the top hinge forward, remove the door and save it aside.

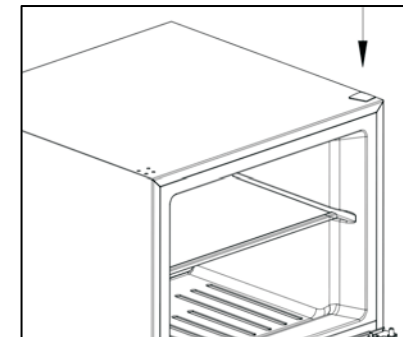
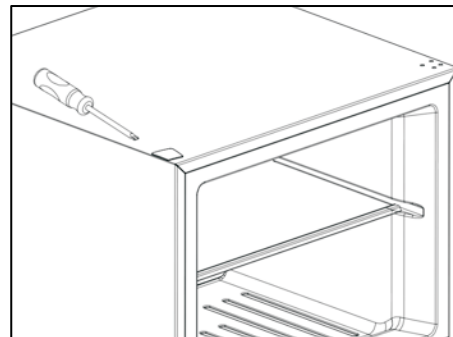

6. Pry off the screw cover on the top left side of the refrigerator to uncover the screws holes.
7. Replace screw cover on the top left side of the refrigerator to the right top to cover the holes. Cover si also force-fitted.

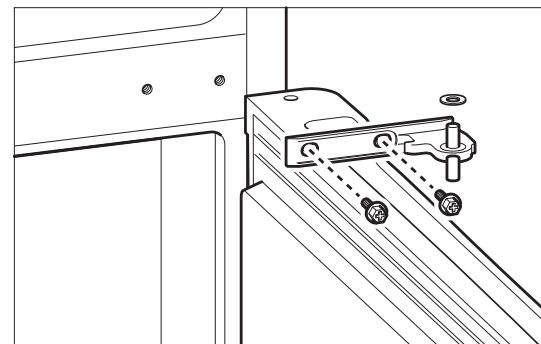

8. Open the bottom door.
9. Take off the 2 screws and save them.
10. Remove the middle hinge.
11. Take out the bottom door and save it.

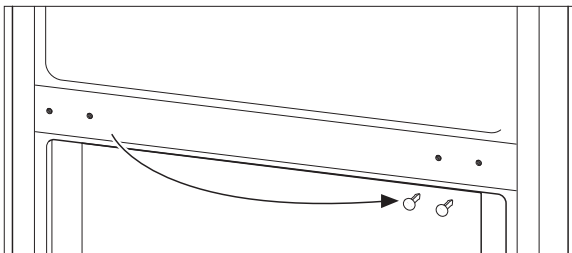

12. Pry off and remove the cover over the screw holes on the left side of refrigerator housing. Attach cover on the right side. Cover is force-fitted.

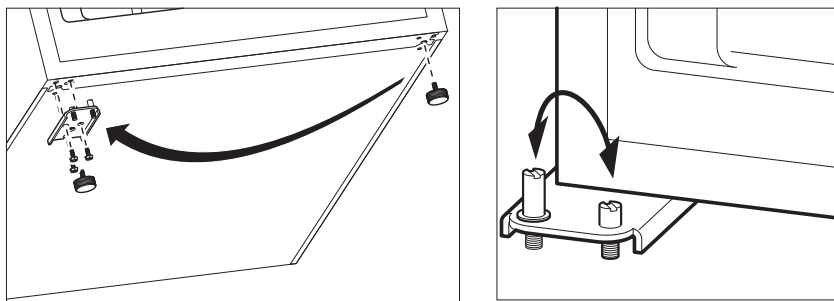

13. Slightly backward the machine against the wall.
14. Take off the 2 fixed feet
15. Take off the bottom hinge.
16. Assemble the bottom hinge in the other side of the machine.
17. Fixed up the feet.
18. Exchange the 2 bolts and fixed them in the other sides.

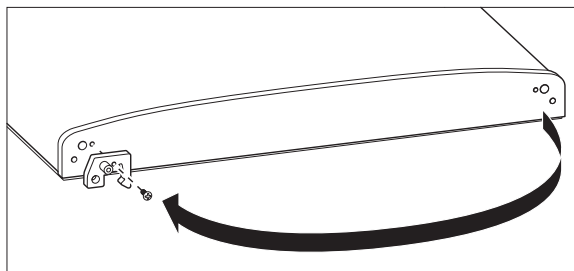

19. Remove the fixed plate of hinge on the bottom door, and fix it on the other side.
20. Fix up the bottom door on the outside bolts.

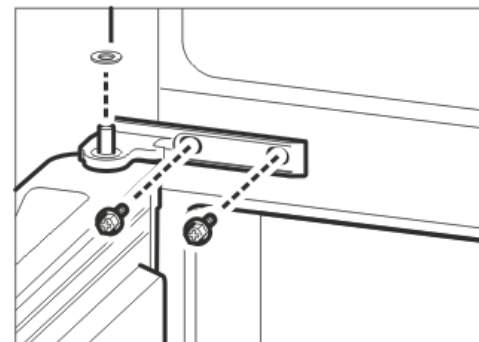

21. Fix up the middle hinge on the bottom door, position it on left side of the refrigerator and reattach with two screws.

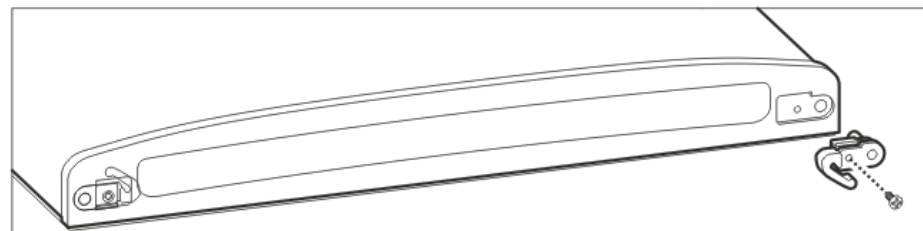

22. Take off the right door closer and fix the left closer in the other side of the upper door.

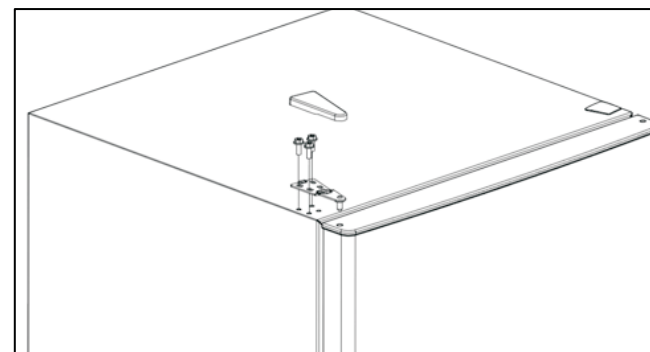

23. Place the top hinge on top of the freezer door and line up the top hinge with holes on top of the refrigerator. Use three screws to replace the hinge. Then tighten the screws. Force-fit protective covers over top hinge.

# OPERATION INSTRUCTIONS

## PLACEMENT OF FOOD

1. There should always be some space between items inside for air circulation.
2. Food should be kept in sealed package to avoid becoming dry or with odour.
3. Hot food should be cooled down before placing into the appliance. Otherwise, interior temperature and electronic consumption will increase.
4. Reduce the frequency of door opening can efficiently low down the electronic consumption.

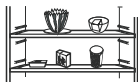

Warning Do not use any electronic equipment inside the appliance.

## INSTRUCTION FOR USAGE

### REFRIGERATOR CONTROL

The temperature of refrigerator can be controlled manually by the display. However, the number shown on the display does not directly represent the temperature. Instead, the larger the number is the lower the interior temperature will be. Initially set the refrigerator control on the middle setting (number 3). If you want to set the refrigerator temperature to a colder temperature pressing the set button until the state on 4 or 5. Each time the set button is pressed, the state increases by 1. When the state is in the highest state, press the button again and return to the first state.

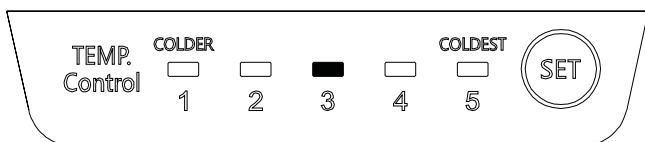

### FREEZER CONTROL

If the refrigerator's lower temperature is needed, please regulate the knob along the "COLDER" direction; contrarily, regulate the knob along the "COLD" direction. Note: Regulate the knob to set the freezer temperature as you desire. Always wait 24 hours after any adjustment to reach the desired temperature.

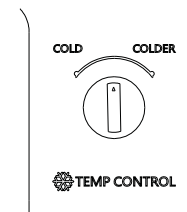

## PACKING AND MOVING

1. Unpack, repack and carry. Please memorize the position of each accessory of the appliance when unpack it, repack the product and check it carefully before transportation.
2. Do not lift or pull the door or the door handle during transportation.
3. When moving, the appliance can not be sloped over 45 degrees (the angle to the vertical direction). Please avoid strong vibration and hit.

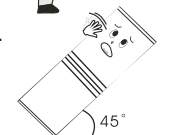
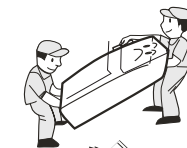

## MAINTENANCE

The appliance should be maintained and cleaned frequently. For your safety, do please pull the plug out of the socket before the cleaning.

1. Interior maintenance  
Clean the interior of the appliance with clean water or neutral abluent. Scour it with clean water and wipe it with a piece of dry cloth.
2. Maintenance of door gasket  
It is easy to damage if the door gaskets are polluted by the stain like oil, sauce and etc., so it is better to clean them carefully.
3. Outer maintenance  
Wipe the dusty with a piece of dry cloth, clean it with neutral abluent if necessary.

## DEFROST

1. Defrost of refrigerator will be executed automatically during product running, so it is no requirement for manual defrost. The defrost water flows into the vaporization plate and will be vaporized by the heat of compressor. So its drain tube must be cleaned.
2. The defrosting type of the product is variable defrosting, with a minimum defrosting interval of 12 hours and a maximum defrosting interval of 96 hours.



Warning Do not use mechanical devices or other means to accelerate the defrosting process, other than those recommended by the manufacturer

## DISCONNECTING THE APPLIANCE

After power failure, even in summer, the refrigerator can store food normally in several hours.

1. Discontinuation during power failure  
After power failure, do not put additional food in the appliance and reduce the frequency of door opening. Make several ices in a container if know the power failure beforehand, and put it in the top of the fridge.
2. Discontinuation during vacation  
Please fetch out the easy-rot food and the food in fridge before shot vacation. After confirmation, close the door firmly. If have a long vacation, please fetch out all the food and cut off the power. After defrosting, clean up the liner of the appliance and wipe it dry, and leave the door open.
3. Stop using  
If the refrigerator may be stopped using for a long time, please unplug the outlet and clean up the appliance. The door should be kept open in order to prevent unpleasant smell caused by food leavings.



Attention

In a general condition, do not stop the appliance in case of affecting its life. After unplugging the power, please leave at least 5 minutes before resumption.

## USER NOTIFICATIONS

1. Do not splash water on the refrigerator, as it will cause oxidation and malfunction. Electronic component such as on/off button should be wiped dryly.
2. Cleansers such as soap powder, abrasive cleaning powder, alkali cleansers, chemical cloth, thinner, alcohol, acid petroleum product and hot water should not be used to clean the refrigerator as they may damage the painted cover and plastics.
3. Smear can damage the interior plastic component, so wipe it as soon as possible.
4. Please check the points below after maintenance:
  - (1) Is there any damage or loss of the electronic wire ?
  - (2) Can the plug be put in the socket reliably and smoothly?
  - (3) Is the plug heating unconventionally?



Warning

Please get rid of the gasket of the door before the disposal. The disposed apparatus should be handled by professional staff, as it may be harmful to the environment.

## TROUBLESHOOTING TIPS

1. The refrigerator does not work  
It may not be connected to the power supply (plug, power cut or fuse); Voltage is too low.
2. The refrigerator does not work efficiently as expected  
It may be caused by heavy frost, or by warm temperature setting, or by frequently door operating.
3. It makes unusual noise  
It may be caused by an imbalance or loose ground locating the appliance, or by resonance between the appliance and other ambient objects.
4. The compressor keeps working for a long period  
The environment temperature may be too high. The doors may be opened frequently or even they are left open. The temperature control knob setting in (4-5) state may increase the working time of compressor.
5. Disgusting odour happens  
Food with strong odour should be packed tightly before being put inside the appliance. Please check whether there is any deteriorated item or whether the liners are left dirty for a long time.
6. Water leaks from the bottom of the refrigerator  
The drain tube is jammed. Please use a proper tool to solve it.
7. Heavy frost occurs on the rear of the appliance  
Putting humid or hot food into the appliance may cause this problem. Or it may be caused by the heavy environment moisture.

No	Defect	LED1-LED5	Description
1	Refrigeration Sensor Failure	●●○○○	Indicated LEDs will flash intermittently at 0.5s intervals.
2	Defrost Sensor Failure	○●●○○	
3	Fan Failure	○○●●○	
4	Overheating Failure	●○○○○ ○●○○○ ○○●○○ ○○○●○ ○○○○●	One of Indicated LEDs will flash intermittently at 0.5s intervals.

## The follow cases are not malfunction

1. Moisture may form dew on the outside of the product during the humid season, just get it wiped.
2. The flow of refrigerant through the pipeline coil can cause a bicker.
3. It is normal that the sides of product get warm as a result of the cooling pipeline working.
4. The frame of the appliance will be warm during working by the defrost pipeline inside it.

**Please check the points above first.**

**If the supply cord is damaged, it must be replaced by the manufacturer, its service agent or similarly qualified persons in order to avoid a hazard.**

## SPECIFICATIONS AND PARAMETERS

Climate class		SN/N/ST
Electric shock protection type		I
Capacity	Freezer	70L
	Refrigerator	210L
Voltage (V)		220-240
Frequency (Hz)		50
Current (A)		0.85
Voice(class)		D
Refrigerant		R600/35g
Interior temperature (°C)	Freezer	≤ -18
	Refrigerator	0~8
Dimension (mm)	Width	599
	Depth	653
	Height	1517

## HINTS AND TIPS

### HINTS FOR ENERGY SAVING

1. Freezer: The internal configuration of the appliance is the one that ensures the most efficient use of energy.
2. Fridge: Most efficient use of energy is ensured in the configuration with the drawers in the bottom part of the appliance and shelves evenly distributed. Position of the door bins does not affect energy consumption.
3. Do not open the door frequently or leave it open longer than necessary.
4. Freezer: The colder the temperature setting, the higher the energy consumption.
5. Fridge: Do not set too high temperature to save energy unless it is required by the characteristics of the food.
6. If the ambient temperature is high and the temperature control is set to low temperature and the appliance is fully loaded, the compressor may run continuously, causing frost or ice formation on the evaporator. In this case, set the temperature control toward higher temperature to allow automatic defrosting and to save energy this way.
7. Ensure a good ventilation. Do not cover the ventilation grilles or holes.

### HINTS FOR FREEZING

1. Before freezing wrap and seal fresh food in: aluminium foil, plastic film or bags, airtight containers with lid.
2. For more efficient freezing and thawing divide food into small portions.
3. It is recommended to put labels and dates on all your frozen food. This will help to identify foods and to know when they should be used before their deterioration.
4. The food should be fresh when being frozen to preserve good quality. Especially fruits and vegetables should be frozen after the harvest to preserve all of their nutrients.
5. Do not freeze bottles or cans with liquids, in particular drinks containing carbon dioxide -they may explode during freezing.
6. Do not put hot food in the freezer compartment. Cool it down at room temperature before placing it inside the compartment.
7. To avoid increase in temperature of already frozen food, do not place fresh unfrozen food directly next to it. Place food at room temperature in the part of the freezer compartment where there is no frozen food.
8. Do not eat ice cubes, water ices or ice lollies immediately after taking them out of the freezer. Risk of frostbites.
9. Do not re-freeze defrosted food. If the food has defrosted, cook it, cool it down and then freeze it.

### HINTS FOR STORAGE OF FROZEN FOOD

- Higher temperature setting inside the appliance may lead to shorter shelf life.
- The whole freezer compartment is suitable for storage of frozen food products.
- Leave enough space around the food to allow air to circulate freely.
- For adequate storage refer to food packaging label to see the shelf life of food.
- It is important to wrap the food in such a way that prevents water, humidity or condensation from getting inside.

## SHOPPING TIPS

After grocery shopping:

- Ensure that the packaging is not damaged - the food could be deteriorated. If the package is swollen or wet, it might have not been stored in the optimal conditions and defrosting may have already started.
- To limit the defrosting process buy frozen goods at the end of your grocery shopping and transport them in a thermal and insulated cool bag.
- Place the frozen foods immediately in the freezer after coming back from the shop.
- If food has defrosted even partially, do not refreeze it. Consume it as soon as possible.
- Respect the expiry date and the storage information on the package.

## SHELF LIFE FOR FREEZER COMPARTMENT

Type of food	Shelf life (months)
Bread	3
Fruits (except citrus)	6 - 12
Vegetables	8 - 10
Leftovers without meat	1 - 2
<b>Dairy food:</b>	
Butter	6 - 9
Soft cheese (e.g. mozzarella)	3 - 4
Hard cheese (e.g. parmesan, cheddar)	6
<b>Sea food:</b>	
Fatty fish (e.g. salmon, mackerel)	2 - 3
Lean fish (e.g. cod, flounder)	4 - 6
Shrimps	12
Shucked clams and mussels	3 - 4
Cooked fish	1 - 2
<b>Meat:</b>	
Poultry	9 - 12
Beef	6 - 12
Pork	4 - 6
Lamb	6 - 9
Sausage	1 - 2
Ham	1 - 2
Leftovers with meat	2 - 3

## HINTS FOR FRESH FOOD REFRIGERATION

Good temperature setting that ensures preservation of fresh food is a temperature less than or equal to +4°C.

Higher temperature setting inside the appliance may lead to shorter shelf life of food.

- Cover the food with packaging to preserve its freshness and aroma.
- Always use closed containers for liquids and for food, to avoid flavours or odours in the compartment.
- To avoid the cross-contamination between cooked and raw food, cover the cooked food and separate it from the raw one.
- It is recommended to defrost the food inside the fridge.
- Do not insert hot food inside the appliance.

Make sure it has cooled down at room temperature before inserting it.

- To prevent food waste the new stock of food should always be placed behind the old one.

## HINTS FOR FOOD REFRIGERATION

Meat (all types): wrap in a suitable packaging and place it on the glass shelf above the vegetable drawer. Store meat for at most 1-2 days.

- Fruit and vegetables: clean thoroughly (eliminate the soil) and place in a special drawer(vegetable drawer).
- It is advisable not to keep the exotic fruits like bananas, mangos, papayas etc. in the refrigerator.
- Vegetables like tomatoes, potatoes, onions, and garlic should not be kept in the refrigerator.
- Butter and cheese: place in an airtight container or wrap in an aluminium foil or a polythene bag to exclude as much air as possible.
- Bottles: close them with a cap and place them on the door bottle shelf, or (if available) on the bottle rack.
- Always refer to the expiry date of the products to know how long to keep them.

## TECHNICAL DATA

---

The technical information is situated in the rating plate on the internal side of the appliance and on the energy label.

The QR code on the energy label supplied with the appliance provides a web link to the information related to the performance of the appliance in the EU EPREL database. Keep the energy label for reference together with the user manual and all other documents provided with this appliance.

It is also possible to find the same information in EPREL using the link <https://eprel.ec.europa.eu> and the model name and product number that you find on the rating plate of the appliance.

See the link [www.theenergylabel.eu](http://www.theenergylabel.eu) for detailed information about the energy label.



## INFORMATION FOR TEST INSTITUTES

---

Installation and preparation of the appliance for any EcoDesign verification shall be compliant with EN 62552. Ventilation requirements, recess dimensions and minimum rear clearances shall be as stated in this User Manual at Chapter 3. Please contact the manufacturer for any other further information, including loading plans.

## ENVIRONMENTAL CONCERNS

---

Recycle materials with the symbol . Put the packaging in relevant containers to recycle it. Help protect the environment and human health by recycling waste of electrical and electronic appliances. Do not dispose of appliances marked with the symbol  with the household waste. Return the product to your local recycling facility or contact your municipal office.

## PACKING LIST

---

Parts	Number
Shelve	3pcs
Crisper glass cover	1pcs
Vegetable crisper	1pcs
Rod	4pcs
Cola bar	2pcs
Bottle protector	2pcs
Owner's manual	1pcs

**Note:** Products are subject to improve from time to time, any changes in parts without further notice.

Table 1 Climate classes

Class	Symbol	Ambient temperature range °C
Extended temperate	SN	+ 10 to + 32
Temperate	N	+ 16 to + 32
Subtropical	ST	+ 16 to + 38
Tropical	T	+ 16 to + 43

Extended temperate: 'this refrigerating appliance is intended to be used at ambient temperatures ranging from 10 °C to 32 °C';

temperate: 'this refrigerating appliance is intended to be used at ambient temperatures ranging from 16 °C to 32 °C';

Subtropical: 'this refrigerating appliance is intended to be used at ambient temperatures ranging from 16 °C to 38 °C';

Special for new European standard:

The ordered parts in the following table can be acquired from channel \_:

**AMIRIDIS-SAVVIDIS S.A.**  
**87A, 17th November str**  
**55535, Pylea, Thessaloniki**  
**+302310944944**

Ordered Part	Provided by	Minimum Time Required for Provision
thermostats	Professional maintenance personnel	At least 7 years after the last model is launched on the market
temperature sensors	Professional maintenance personnel	At least 7 years after the last model is launched on the market
printed circuit boards	Professional maintenance personnel	At least 7 years after the last model is launched on the market
light sources	Professional maintenance personnel	At least 7 years after the last model is launched on the market
door handles	Professional repairers and final users	At least 7 years after the last model is launched on the market
door hinges	Professional repairers and final users	At least 7 years after the last model is launched on the market
trays	Professional repairers and final users	At least 7 years after the last model is launched on the market
baskets	Professional repairers and final users	At least 7 years after the last model is launched on the market
door gaskets	Professional repairers and final users	At least 10 years after the last model is launched on the market

- The shortest period for providing after-sales spare parts is 15 working days.
- The model information and model identification in the product database can be obtained by scanning the web link on the QR code (if any) on the product energy efficiency label.

### Dear customer

1. If you want to return or replace the product, please contact the store where you buy.  
(Remember to bring the purchase invoice)
2. If your product breaks down which needs to repair, please contact after-sales service provider.

### NOTICE ABOUT RECYCLING



Your product is designed and manufactured with high quality materials and components which can be recycled and reused.

This symbol means that electrical and electronic equipment, at their end-of-life,

should be disposed of separately from your household waste. Please dispose of this equipment at your local community waste collection/ recycling centre.

In the European Union there are separate collection systems for used electrical and electronic products.

Please help us to conserve the environment we live in!

### DECLARATION OF CONFORMITY

Herewith, we state that this product complies with the requirements of below directives:



EMC-Directive: 14 / 30 / EU

Low Voltage Directive: 14/ 35 / EU

ErP Directive 09 / 125 / EC

CE Marking: 93 / 68 / EEC

RoHS Directive: 11 / 65 / EU & Delegated Directive (EU) 15 / 863

The detailed declaration of conformity can be found at

[www.united-electronics.gr](http://www.united-electronics.gr)